

# Wireless Sensing Triple-Axis Reference Design (ZSTAR)

## Target Applications

The ZSTAR design provides small portable boards with the capability to demonstrate and evaluate various accelerometer applications that accommodate the cost-effective, low-power wireless connection. Applications include:

- Mobile phones
- Handheld gaming devices
- Portable media players
- MP3 players
- PDAs
- Personal computer peripherals
- GPS navigation devices
- Health care devices
- Toys
- Robotics

## Overview

With more than 50 years of industry leadership in developing semiconductor products, Freescale is exceptionally qualified to showcase the latest innovations in embedded flash microcontrollers (MCUs), sensors, software and wireless connectivity in a flexible development tool.

Freescale's RD3152MMA7260Q ZSTAR can help you streamline your solution with the convenience of motion and wireless control. The software is designed to allow visualization of key applications in the consumer industry. The ZSTAR is a small two-board portable design that utilizes the following products:

- MMA7260QT triple-axis accelerometer
- MC9S08QG8 8-bit MCU
- MC1319x 2.4 GHz low-power transceivers
- MC68HC908JW32 USB 2.0 Full Speed 8-bit MCU

The tool contains all of the hardware, software and documentation necessary to enable you to see how Freescale accelerometers, MCUs and wireless products can add additional functionality to applications.

Features	Benefits
Multi-axis acceleration sensor	<ul style="list-style-type: none"> <li>• Low power for extended battery life</li> <li>• Flexibility to select g-range of acceleration for multifunctional applications</li> <li>• Fast power-up response time</li> </ul>
MC9S08QG8 MCU	<ul style="list-style-type: none"> <li>• Highly integrated and versatile</li> <li>• Easy interface for analog inputs, such as sensors</li> <li>• Provides single-wire debugging and emulation interface</li> </ul>
MC1319x 2.4 GHz low-power transceivers	<ul style="list-style-type: none"> <li>• Simple, cost-effective solution for fast time to market</li> <li>• 2.4 GHz allows global deployment</li> <li>• Enables simple wireless connectivity</li> </ul>
MC68HC908JW32 USB 2.0 Full Speed 8-bit MCU	<ul style="list-style-type: none"> <li>• Available with a variety of memory sizes and types, modules and packages</li> <li>• Easy to learn and use architecture</li> <li>• C-optimized architecture provides compact code</li> </ul>
Low-power, low-current operation	<ul style="list-style-type: none"> <li>• Battery life extension</li> </ul>
Software support	<ul style="list-style-type: none"> <li>• Easy development</li> </ul>

## ZSTAR Sensor Board View

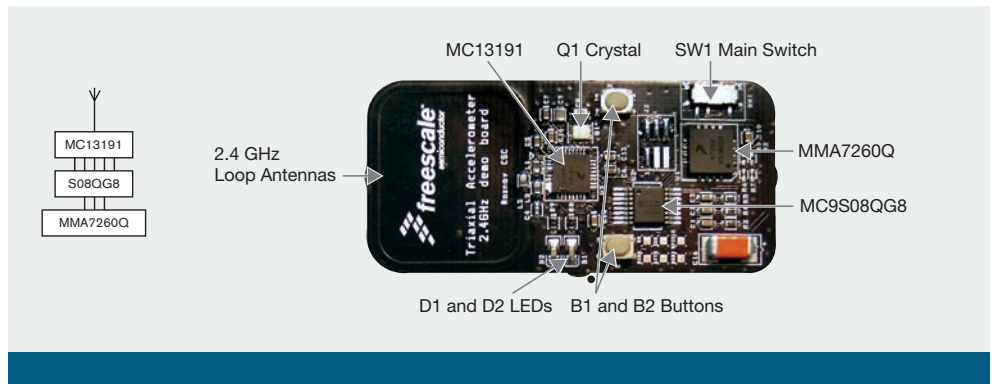

## ZSTAR USB Stick Board View

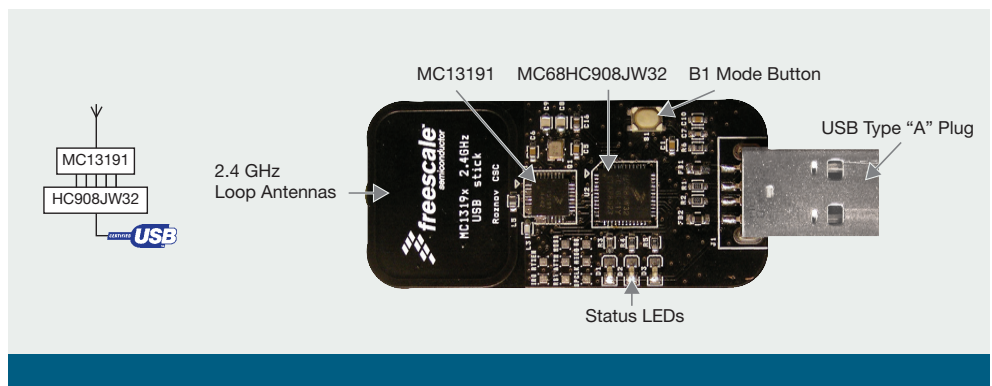

## Application Notes

AN3152	Using the Wireless Sensing Triple Axis Reference Design
AN3112	Using the Sensing Triple-Axis Reference Design (STAR)
AN3107	Measuring Tilt with Low-g Accelerometers
AN2731	Compact, Integrated Antennas: Designs and Applications for the MC13191 and MC13192
AN2728	Demonstration Guide for SMAC Applications
AN2295	Developer's Serial Bootloader for M68HC08 and HCS08 MCUs Reference Manual
SMACRM	Simple Media Access Controller (SMAC) User's Guide

## Data Sheets

MMA7360L	1.5 or 6g XYZ-Axis Low-g Accelerometer
MMA7340L	3 or 12g XYZ-Axis Low-g Accelerometer
MMA7330L	4 or 16g XYZ-Axis Low-g Accelerometer
MMA7260Q	+/- 1.5g–6g XYZ-Axis Low-g Accelerometer
MMA7261Q	+/- 2.5g–10g XYZ-Axis Low-g Accelerometer
MMA6270Q	+/- 1.5g–6g XY-Axis Low-g Accelerometer
MMA6271Q	+/- 2.5g–10g XY-Axis Low-g Accelerometer
MMA6280Q	+/- 1.5g–6g XZ-Axis Low-g Accelerometer
MMA6281Q	+/- 2.5g–10g XZ-Axis Low-g Accelerometer
MC13191	2.4 GHz Low-Power Transceiver
MC9S08QG8	MC9S08QG8 Microcontroller Unit
MC68HC908JW32	MC68HC908JW32 Microcontroller Unit

## Reference Designs

RD3152MMA7260Q	RD3152MMA7260Q ZSTAR
RD3112MMA7260Q	RD3112MMA7260Q STAR

The ZSTAR design provides two small portable boards with the capability to demonstrate and evaluate various accelerometer applications that accommodate the cost-effective, low-power wireless connection.

Benefits include:

- A multi-axis acceleration sensor that enables multiple detection situations for potential applications and includes a g-select feature with a 1.5g–10g range
- The highly integrated and versatile MC9S08QG8 MCU includes a background debugging system and on-chip in-circuit emulation (ICE) with real-time bus capture—providing single-wire debugging and emulation interface

- The MC13191/MC13192/MC13193 2.4 GHz low-power transceivers provide a cost-effective solution for short-range data links and networks
- The MC68HC908JW32 MCU is in the family of the enhanced M68HC08 CPU (CPU08) and is available with a variety of memory sizes and types, modules and package types
- Battery life extension through low-power, low-current operation
- Software support for easy development

### ZSTAR Sensor Board Software Overview—MC9S08QG8

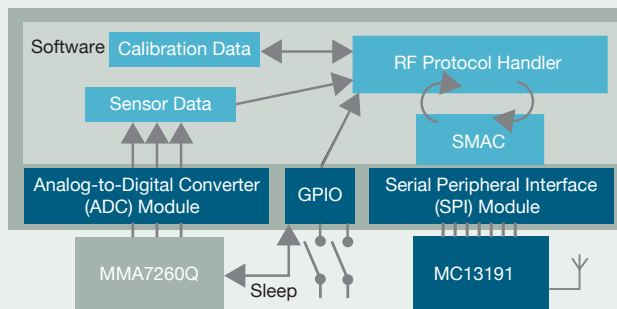

### ZSTAR USB Stick Software Overview—MC68HC908JW32

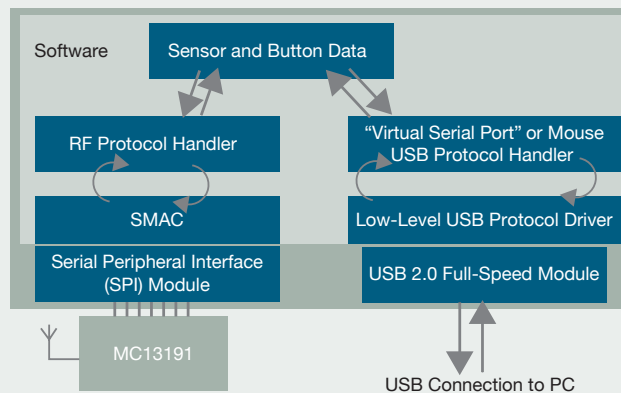

## Learn More:

For current information about Freescale products and documentation, please visit [www.freescale.com](http://www.freescale.com).